

> Bolting Systems®

HIGH CYCLE HYDRAULIC TORQUE WRENCH

UP TO 71,816 NM @ 700 BAR (53,000 LBFT @ 10,000 PSI)

Designed for high cycle quality
and lower cost of ownership



The TWHC's designed long-stroke mechanism imparts a 30 degree nut rotation per stroke while maintaining a tight and compact nose radius: this is a clear advantage over the short stroke and backup pawl mechanisms of light-alloy competitive models. Fewer parts and reduced torsion in operation equals reduced wear, maintenance, and associated costs.

Enhanced Usability

- Compact nose radius allows the tool to fit in tighter, hard-to-reach spaces
- Low weight, high strength design
- Fast operation, long stroke and optimum flow
- Multi-direction high flow swivel manifold, with threaded couplers for maximum flow performance
- Tool free square drive reversal and Reaction Arm positioning

Designed with Safety in Mind

- Fully enclosed drive mechanism for operator safety
- Swivel manifold internal relief valve prevents retract side over-pressurization
- Fine tooth pawl prevents tool 'lock-on'

Quality means Lower Life-Cycle Costs

- Designed for high cycle life: 2-3x more than existing technology
- Increased reliability: Simple drive assembly means less downtime
- Corrosion resistant material for use in harsh environments including offshore and subsea



SPXFLOW®

Specifications and Dimensional Data

Model	Min Torque		Max Torque		Sq. Drive	A	B	C	D	E	F	G	H	I	Weight	
	lb-ft	Nm	lb-ft	Nm	In	Millimeters (Inches)										Kg
TWHC1	170	230	1413	1915	3/4	132 (5.20)	145 (5.71)	28 (1.10)	111.5 (4.39)	170.0 (6.69)	39.5 (1.56)	67.7 (2.67)	86.1 (3.39)	M6 X 1.0	2.8	6.2
TWHC3	376	510	3136	4249	1	165 (6.50)	173.5 (6.83)	36.5 (1.44)	129.6 (5.10)	197.7 (7.78)	53 (2.09)	83.7 (3.30)	105.1 (4.14)	M6 X 1.0	5.3	11.7
TWHC6	726	982	6050	8198	1½	192 (7.56)	201.6 (7.94)	44 (1.73)	158.5 (6.24)	243.7 (9.59)	61 (2.40)	99.9 (3.93)	135.1 (5.32)	M8 X 1.25	8.8	19.4
TWHC11	1336	1811	11134	15095	1½	231 (9.09)	233 (9.18)	53 (2.07)	186 (7.34)	300 (11.81)	86 (3.39)	130 (5.12)	207 (8.16)	M8 X 1.25	15.9	34.9
TWHC20	2439	3305	20325	27541	2½	280 (11.01)	310 (12.21)	64 (2.52)	220 (8.65)	364 (14.34)	94 (3.68)	155 (6.10)	212 (8.35)	M12 X 1.75	27.5	60.8
TWHC35	3890	5271	32418	43927	2½	340 (13.40)	346 (13.61)	78 (3.05)	251 (9.90)	425 (16.73)	121 (4.74)	182 (7.15)	228 (8.97)	M12 X 1.75	46.3	102
TWHC50	6360	8628	53000	71816	2½	404.5 (15.93)	356.6 (14.04)	88 (3.46)	266.5 (10.49)	446.6 (17.58)	115 (4.53)	192.2 (7.57)	258 (10.16)	M12 X 1.75	69	152

* Dimension I shows thread size (on both sides of the tool) for safety handle or lifting point.
 *TWHC20, TWHC35, and TWHC50 models available with lifting points only.

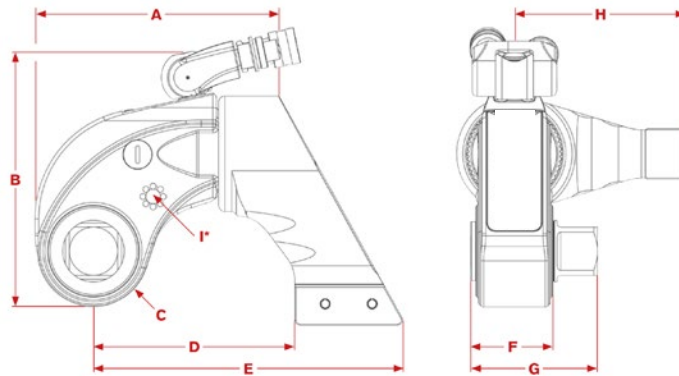

TWHC Accessories



TWHC-ERA
Extended Reaction Arm



TWHC Handle
TWHC1, TWHC3:
DFTAS000001
TWHC6, TWHC11:
DFTAS000002



TWHC-RP
Reaction Pad



TWHC Hex Drives



TWHC-LRA
Long Reaction Arm



SPX FLOW, Inc. reserves the right to incorporate our latest design and material changes without notice or obligation. Design features, materials of construction and dimensional data, as described in this bulletin, are provided for your information only and should not be relied upon unless confirmed in writing. Please contact your local sales representative for product availability in your region. The green "➤" is a trademark of SPX FLOW, Inc.

Distributed by:



For our full range of Torque & Bolting equipment including Pumps, Hoses & Bolt Tensioning Systems, visit www.spxflow.com/bolting-systems

P: (800) 541-1418 ▪ E: info@spxboltingsystems.com | 5885 11th Street ▪ Rockford, IL 61109 U.S.A

BT_TWHC_0223_US | VERSION 02/2023 | COPYRIGHT © 2023 SPX FLOW, Inc.